

<b>de</b>	Kurzanleitung
<b>en</b>	Quick guide
<b>fr</b>	Prise en main rapide
<b>sv</b>	Snabbguide
<b>nl</b>	Wegwijzer
<b>it</b>	Guida rapida
<b>es</b>	Guía Rápida
<b>fi</b>	Pikaopas
<b>da</b>	Quick guide
<b>cs</b>	Stručný návod
<b>el</b>	Σύντομος οδηγός
<b>tr</b>	Hızlı Kılavuz

## Smart Valve Actuator

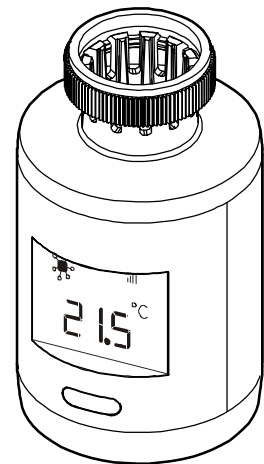

<http://www.siemens.com/smart-thermostat>



### SSA911.01TH

<b>A</b>	<b>de</b>	Hinweise / Warnungen	<b>nl</b>	Aanwijzingen / Waarschuwingen	<b>da</b>	Bemærkninger / Advarsler
	<b>en</b>	Notes / Warnings	<b>it</b>	Indicazioni / Avvertenze	<b>cs</b>	Poznámky / Varování
	<b>fr</b>	Indications / Mises en garde	<b>es</b>	Indicaciones / Consejos	<b>el</b>	Σημειώσεις / Προειδοποιήσεις
	<b>sv</b>	Hänvisningar / Varningar	<b>fi</b>	Huomautuksia / Varoituksia	<b>tr</b>	Notlar / Uyarılar

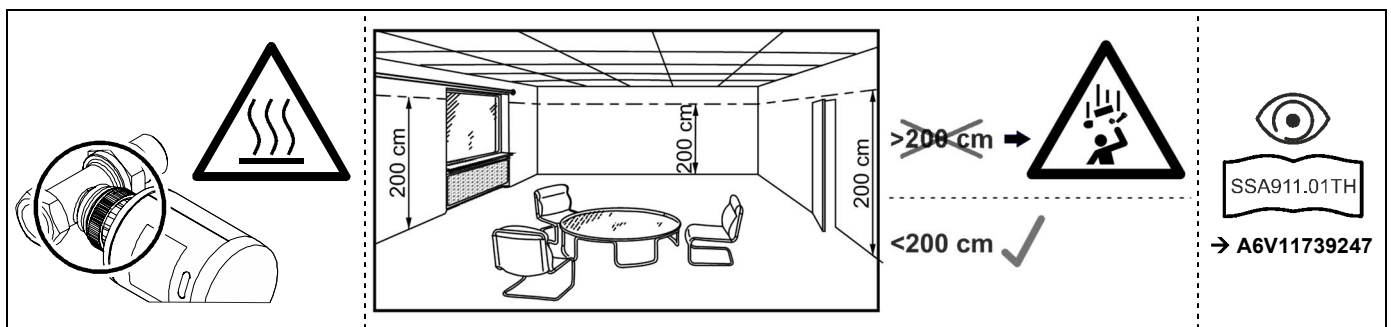

<b>B</b>	<b>de</b>	Montage / Inbetriebnahme	<b>nl</b>	Montage / Inbedrijfstelling	<b>da</b>	Montering / Idriftsættelse
	<b>en</b>	Mounting / Commissioning	<b>it</b>	Montaggio / Messa in servizio	<b>cs</b>	Montáž / Uvedení do provozu
	<b>fr</b>	Montage / Mise en service	<b>es</b>	Montaje / Puesta en marcha	<b>el</b>	Τοποθέτηση / Ρύθμιση
	<b>sv</b>	Montering / Igångkörning	<b>fi</b>	Asennusohje / Käyttöönotto	<b>tr</b>	Montaj / Devreye alma

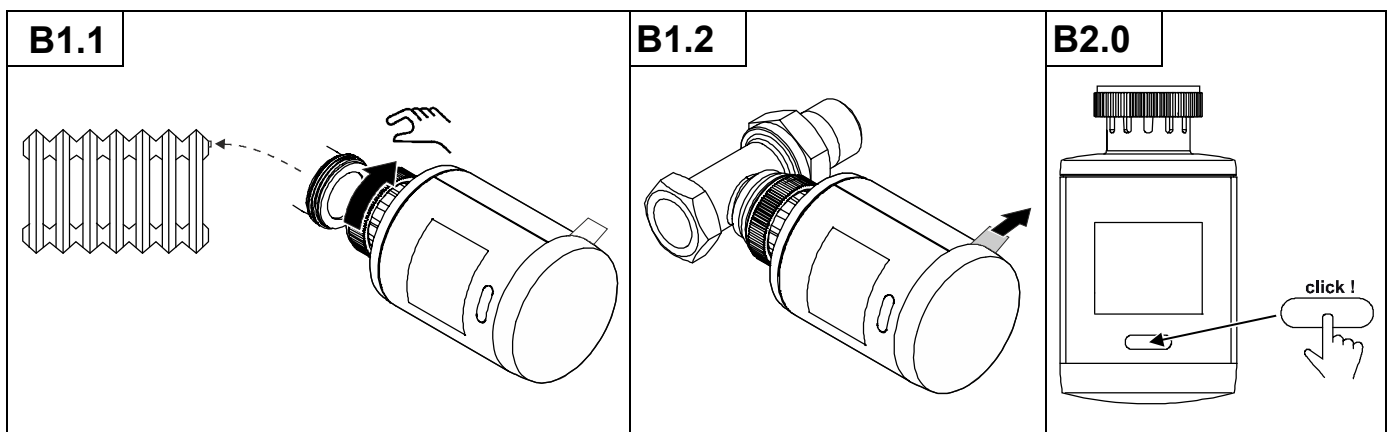

**B2.1**

SSA911.01TH

⚠ E36

> 2 s

→ ●

Go

→ ●

→ ● ✓

**B2.2**

RDS110.R

RDS110.R → A5W90008183

**B2.3**

SSA911.01TH

> 2 s

~ 30 s











Go

**B2.4**

RDS110.R

<b>C</b>	<b>de</b> Bedienung	<b>nl</b> Operatie	<b>da</b> Betjening
	<b>en</b> Operation	<b>it</b> Operazioni	<b>cs</b> Ovládání
	<b>fr</b> Opération	<b>es</b> Funcionamiento	<b>el</b> Λειτουργία
	<b>sv</b> Betjäning	<b>fi</b> Käyttöohje	<b>tr</b> Çalıştırma

<p>&lt; 1 s</p> <p>21.5 °C</p>	Statusinformationen anzeigen	Statusinformatie tonen	Vis statusinformation
	Display status information	Display informazioni di funzionamento	Zobrazení informací o stavu
<p>4...6 s</p>	Afficher les informations d'état	Visualizar información de status	Πληροφορίες οθόνης
	Visning av statusinformation	Näytä tilatiedot	Durum bilgisini göster
	Verbindungstest	Verbindingstest	Forbindelsetest
	Connection test	Test collegamento	Test připojení
	Test de connexion	Prueba de conexión	Δοκιμή σύνδεσης
	Anslutningstest	Yhteystesti	Bağlantı testi

 <b>6...9 s</b>	 *)	Zurücksetzen und neue Kopplung starten	Resetten en nieuwe koppeling starten	Reset og start ny parring
		Reset and start new pairing	Reset e riavvio associazione	Reset a opřetovné připojení
		Démarrer réinitialisation et nouveaux appairage	Restablecer e iniciar un nuevo conexión	Επαναφορά και εκκίνηση νέας σύνδεσης
		Återställning och start av en ny anslutning	Palautus ja aloita uusi pariliitos	Sifirla ve yeni bağlantıyı başlat
 <b>9...12 s</b>	 **)	Anpassen an Ventil	Aanpassen aan klep	Tilpas til ventil
		Adapt to valve	Adattamento alla valvola	Adaptace na ventil
		S'adapter à la vanne	Adaptación a la válvula	Προσαρμογή στη βάνα
		Anpassning till ventilen	Venttiilin sopeutus	Vanaya adapte
 <b>12...16 s</b>	 ***)	Werksrückstellung	Fabrieksreset	Gendan til fabriksindstilling
		Factory reset	Ritorno alle impostazioni di fabbrica	Reset do továrního nastavení
		Réinitialisation d'usine	Reinicio de fábrica	Επαναφορά εργοστασιακών ρυθμίσεων
		Fabriksåterställning	Tehdas palautus	Fabrika sıfırlama
 <b>88.8</b>		Fehlercode	Foutcode	Fejlkode
		Error code	Codice errore	Kód poruchy
		Code d'erreur	Código de error	Κωδικός σφάλματος
		Felkod	Virhekoodi	Hata kodu
 <b>E36</b>	 <b>E40</b>	Mechanischer Fehler	Mechanische fout	Mekanisk fejl
		Mechanical error	Errore meccanico	Mechanická porucha
		Erreur mécanique	Error mecánico	Μηχανικό σφάλμα
		Mekaniskt fel	Mekaaninen virhe	Mekanik hata
 <b>E49</b>		Kein Regler gefunden	Geen controller gevonden	Ingen regulator fundet
		No controller found	Nessun regolatore trovato	Nebyl nalezen žádný regulátor
		Aucun contrôleur trouvé	No encontrado ningún controlador	Δε βρέθηκε θερμοστάτης
		Ingen regulator hittades	Säadintä ei löydetty	Kontrolör bulunamadı
 <b>E53</b>		Verbindungsverlust	Verbinding verbroken	Tabt forbindelse
		Connection lost	Perdita collegamento	Ztráta spojení
		Connexion perdue	Conexión perdida	Απώλεια σύνδεσης
		Anslutning förlurad	Yhteys poikki	Bağlantı kaybı

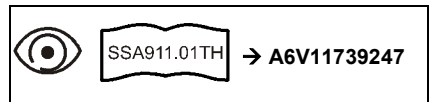
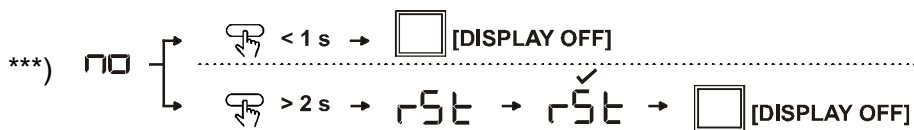
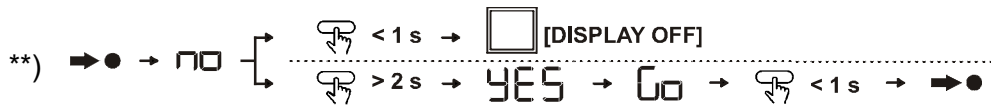
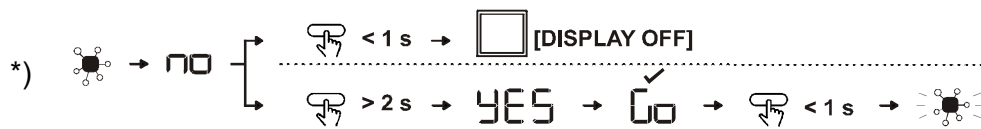

<b>D</b>	de	Batterien austauschen	nl	Batterijen vervangen	da	Udskift batterier
	en	Replacing the batteries	it	Sostituire le batterie	cs	Výměna baterií
	fr	Remplacer les piles	es	Sustitución de las baterías	el	Αντικατάσταση μπαταριών
	sv	Byt ut batterierna	fi	Vaihda paristot	tr	Pilleri değiştirin

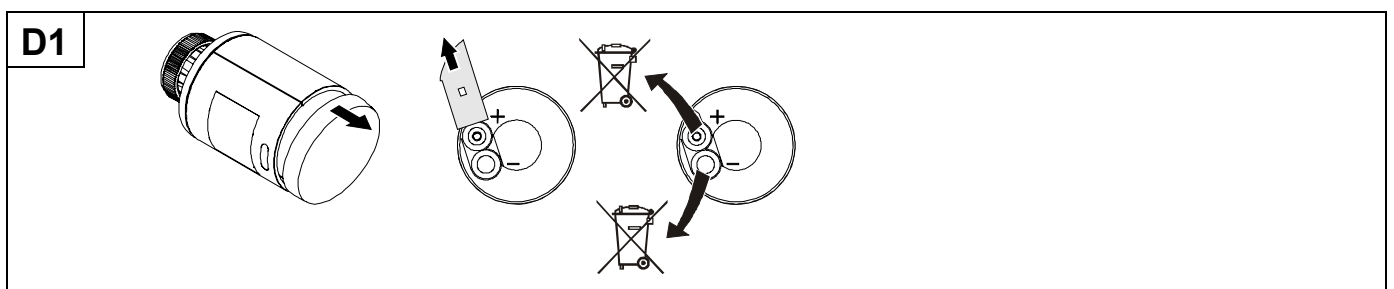

D2

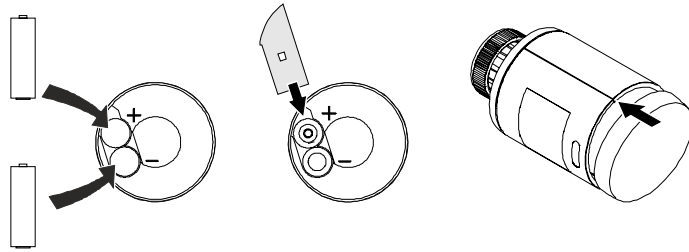

2 x Alkaline LR6

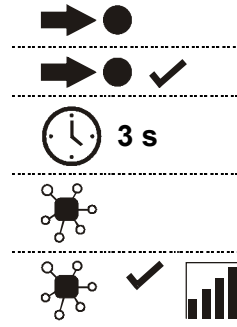

Frequenzbereich / Frequency band / Bande de fréquences / Frekvens band / Frequentieband / Banda di frequenza / Banda de frecuencia / Тајуус / Frekvensbånd / Kmitočtové pásmo / Εύρος συχνότητας / Frekans aralıǵı	2.4...2.4835 GHz
Max. Sendeleistung / Max. transmission power / Puissance de transmission max. / Max. överföringseffekt / Max. zendvermogen / Max potenza di trasmissione / Máx. energía de transmisión / Maksimi lähetysteho / Maks. sendestyrke / Maximální radiofrekvenční výkon / Μέγιστη ισχύς μετάδοσης / Maks. iletim gücü	3.5 dBm

<b>de Vereinfachte EU-Konformitätserklärung</b> Hiermit erklärt Siemens Switzerland Ltd, dass der Funkanlagentyp SSA911.01TH der Richtlinie 2014/53/EU entspricht. Der vollständige Text der EU-Konformitätserklärung ist unter der folgenden Internetadresse verfügbar: <a href="https://siemens.com/bt/download">https://siemens.com/bt/download</a> .	<b>nl Vereenvoudigde EU-conformiteitsverklaring</b> Siemens Switzerland Ltd verklaart hierbij dat het type radioapparatuur SSA911.01TH conform Richtlijn 2014/53/EU is. De volledige tekst van de EU-conformiteitsverklaring kan worden geraadpleegd op het volgende internetadres: <a href="https://siemens.com/bt/download">https://siemens.com/bt/download</a> .	<b>da Forenklet EU-overensstemmelseserklæring</b> Hermed erklærer Siemens Switzerland Ltd, at radioudstyrstypen SSA911.01TH er i overensstemmelse med direktiv 2014/53/EU. EU-overensstemmelseserklæringens fulde tekst kan findes på følgende internetadresse: <a href="https://siemens.com/bt/download">https://siemens.com/bt/download</a> .
<b>en Simplified EU Declaration of Conformity</b> Hereby, Siemens Switzerland Ltd declares that the radio equipment type SSA911.01TH is in compliance with Directive 2014/53/EU. The full text of the EU declaration of conformity is available at the following internet address: <a href="https://siemens.com/bt/download">https://siemens.com/bt/download</a> .	<b>it Dichiarazione di conformità UE semplificata</b> Il fabbricante, Siemens Switzerland Ltd, dichiara che il tipo di apparecchiatura radio SSA911.01TH è conforme alla direttiva 2014/53/UE. Il testo completo della dichiarazione di conformità UE è disponibile al seguente indirizzo Internet: <a href="https://siemens.com/bt/download">https://siemens.com/bt/download</a> .	<b>cs Zjednodušené EU prohlášení o shodě</b> Tímto Siemens Switzerland Ltd prohlašuje, že typ rádiového zařízení SSA911.01TH je v souladu se směrnicí 2014/53/EU. Úplné znění EU prohlášení o shodě je k dispozici na této internetové adrese: <a href="https://siemens.com/bt/download">https://siemens.com/bt/download</a> .
<b>fr Déclaration UE de conformité simplifiée</b> Le soussigné, Siemens Switzerland Ltd, déclare que l'équipement radioélectrique du type SSA911.01TH est conforme à la directive 2014/53/UE. Le texte complet de la déclaration UE de conformité est disponible à l'adresse internet suivante: <a href="https://siemens.com/bt/download">https://siemens.com/bt/download</a> .	<b>es Declaración UE de conformidad simplificada</b> Por la presente, Siemens Switzerland Ltd declara que el tipo de equipo radioeléctrico SSA911.01TH es conforme con la Directiva 2014/53/UE. El texto completo de la declaración UE de conformidad está disponible en la dirección Internet siguiente: <a href="https://siemens.com/bt/download">https://siemens.com/bt/download</a> .	<b>el Απλουστευμένη Δήλωση Συμμόρφωσης ΕΕ</b> Με την παρούσα ο/η Siemens Switzerland Ltd, δηλώνει ότι ο ραδιοεξοπλισμός SSA911.01TH πληροί την οδηγία 2014/53/ΕΕ. Το πλήρες κείμενο της δήλωσης συμμόρφωσης ΕΕ διατίθεται στην ακόλουθη ιστοσελίδα στο διαδίκτυο: <a href="https://siemens.com/bt/download">https://siemens.com/bt/download</a> .
<b>sv Förenklad EU-försäkran om överensstämmelse</b> Härmed försäkrar Siemens Switzerland Ltd att denna typ av radioutrustning SSA911.01TH överensstämmer med direktiv 2014/53/EU. Den fullständiga texten till EU-försäkran om överensstämmelse finns på följande webbadress: <a href="https://siemens.com/bt/download">https://siemens.com/bt/download</a> .	<b>fi Yksinkertaistettu EU-vaatimustenmukaisuusvakuutus</b> Siemens Switzerland Ltd vakuuttaa, että radiolaitetyypin SSA911.01TH on direktiivin 2014/53/EU mukainen. EU-vaatimustenmukaisuusvakuutuksen täysimittainen teksti on saatavilla seuraavassa internetosoitteessa: <a href="https://siemens.com/bt/download">https://siemens.com/bt/download</a> .	<b>tr Basitleştirilmiş AB Uygunluk Beyanı</b> Siemens Switzerland Ltd., SSA911.01TH telsiz teçhizatının 2014/53 / EU Direktifine uygun olduğunu açıkladı. AB Uygunluk Beyanı'nın tam metni aşağıdaki İnternet adresinde mevcuttur: <a href="https://siemens.com/bt/download">https://siemens.com/bt/download</a> .