

# User Manual

**AMBIANO®**

## **25 L MICROWAVE OVEN WITH GRILL & CONVECTION**



# Contents

|                                                |           |
|------------------------------------------------|-----------|
| <b>Overview .....</b>                          | <b>3</b>  |
| <b>Use.....</b>                                | <b>3</b>  |
| <b>Appliance parts .....</b>                   | <b>4</b>  |
| <b>About these operating instructions.....</b> | <b>7</b>  |
| <b>Safety information .....</b>                | <b>9</b>  |
| <b>About microwaves .....</b>                  | <b>19</b> |
| <b>Cooking with the microwave .....</b>        | <b>20</b> |
| <b>Package contents.....</b>                   | <b>23</b> |
| <b>Display .....</b>                           | <b>24</b> |
| <b>Before first use .....</b>                  | <b>25</b> |
| <b>Operation.....</b>                          | <b>27</b> |
| <b>Cleaning and care .....</b>                 | <b>39</b> |
| <b>Storage .....</b>                           | <b>40</b> |
| <b>Troubleshooting.....</b>                    | <b>41</b> |
| <b>Disposal.....</b>                           | <b>41</b> |
| <b>Technical specifications .....</b>          | <b>42</b> |
| <b>Declaration of Conformity.....</b>          | <b>42</b> |
| <b>Service information .....</b>               | <b>43</b> |
| <b>Legal Notice .....</b>                      | <b>44</b> |

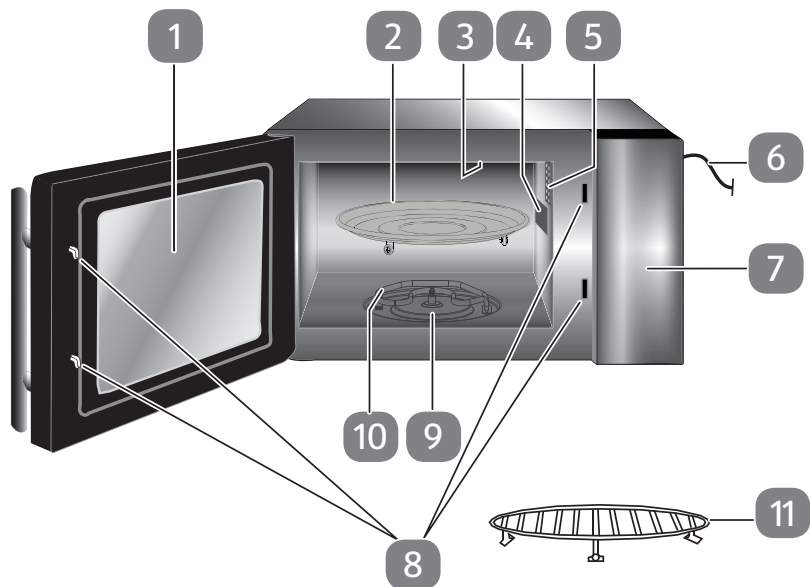
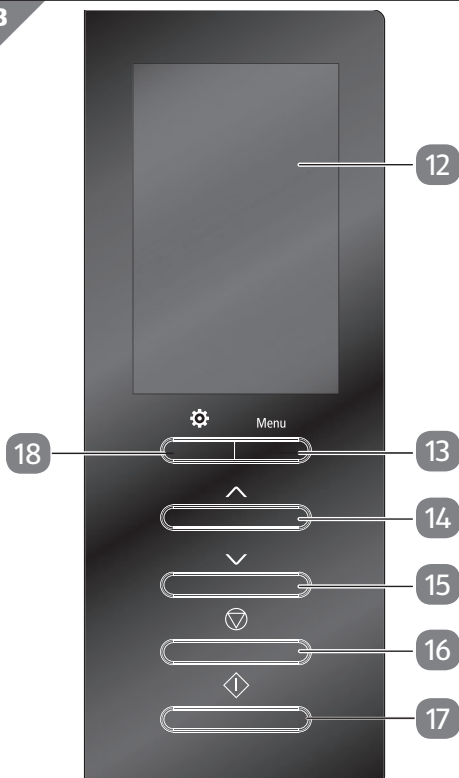
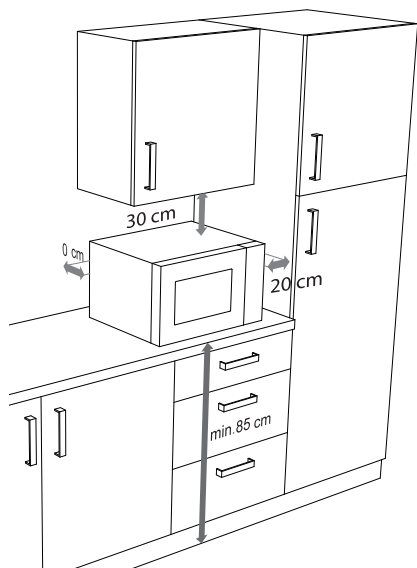
**A****B****C**

# Appliance parts

- 1 Viewing window
- 2 Turntable
- 3 Top grill
- 4 Magnetron cover (DO NOT REMOVE!)
- 5 Light
- 6 Power cord
- 7 Control panel
- 8 Door lock
- 9 Turntable shaft
- 10 Bottom grill
- 11 Grilling rack
- 12 Display: Shows cooking time, power, operating mode and time
- 13 Menu: Set auto program
- 14 Navigate up the menu, set weight/cooking time
- 15 Navigate down the menu, set weight/cooking time
- 16 Cancel input or reset appliance
- 17 Quick start / confirm input / start operation
- 18 Set mode

# Contents

|                                                           |           |
|-----------------------------------------------------------|-----------|
| <b>Overview</b> .....                                     | <b>3</b>  |
| <b>Use</b> .....                                          | <b>3</b>  |
| <b>Appliance parts</b> .....                              | <b>4</b>  |
| <b>About these operating instructions</b> .....           | <b>7</b>  |
| Key to symbols .....                                      | 7         |
| <b>Safety information</b> .....                           | <b>9</b>  |
| Proper use .....                                          | 9         |
| Safety of children and persons .....                      | 9         |
| Hot surfaces .....                                        | 13        |
| Special safety instructions for handling microwaves ..... | 15        |
| Safety instructions for heating liquids .....             | 17        |
| Cleaning and caring for the appliance .....               | 17        |
| <b>About microwaves</b> .....                             | <b>19</b> |
| <b>Cooking with the microwave</b> .....                   | <b>20</b> |
| Microwave-safe materials .....                            | 20        |
| Materials of limited suitability.....                     | 22        |
| Unsuitable materials.....                                 | 22        |
| <b>Package contents</b> .....                             | <b>23</b> |
| <b>Display</b> .....                                      | <b>24</b> |
| <b>Before first use</b> .....                             | <b>25</b> |
| Setting up the appliance.....                             | 25        |
| Heating the empty appliance .....                         | 26        |
| Inserting the accessories .....                           | 26        |
| <b>Operation</b> .....                                    | <b>27</b> |
| Setting the time .....                                    | 27        |
| Setting the kitchen timer (countdown) .....               | 27        |
| Child safety lock.....                                    | 27        |
| Cooking with microwave energy .....                       | 28        |
| Quick start.....                                          | 29        |
| Automatic defrosting by weight or time.....               | 30        |
| Grill or combination mode .....                           | 30        |

## Contents

---

|                                        |           |
|----------------------------------------|-----------|
| Hot air.....                           | 31        |
| Using several programs .....           | 32        |
| Automatic cooking .....                | 32        |
| <b>Cleaning and care.....</b>          | <b>39</b> |
| <b>Storage .....</b>                   | <b>40</b> |
| <b>Troubleshooting.....</b>            | <b>41</b> |
| <b>Disposal .....</b>                  | <b>41</b> |
| <b>Packaging .....</b>                 | <b>41</b> |
| <b>Device .....</b>                    | <b>41</b> |
| <b>Technical specifications.....</b>   | <b>42</b> |
| <b>Declaration of Conformity .....</b> | <b>42</b> |
| <b>Service information.....</b>        | <b>43</b> |
| <b>Legal Notice .....</b>              | <b>44</b> |

## About these operating instructions



Thank you for choosing our product. We hope you enjoy using it.

Read the safety instructions carefully before using the appliance for the first time. Note the warnings on the appliance and in the operating instructions.

Always keep the operating instructions close to hand. If you sell the appliance or give it away, please ensure that you also pass on these operating instructions. They are an essential component of the product.

### Key to symbols

If a block of text is marked with one of the warning symbols listed below, the hazard described in that text must be avoided to prevent the potential consequences described there from occurring.



This keyword denotes a high-risk hazard situation which results in death or serious injury if it is not avoided.



This keyword denotes a medium-risk hazard situation which can result in death or a serious injury if it is not avoided.



This keyword denotes a low-risk hazard situation which can result in moderate or minor injuries if it is not avoided.



This keyword serves as a warning for possible damage to property.



This symbol provides useful additional information for assembling or operating the appliance.



Warning: danger due to hot surfaces!



Comply with the notes in the operating instructions.



AC

**Protective earthing symbol (For protection class I)**



Electrical appliances in protection class I are electrical appliances that have at least basic insulation throughout and have either a plug with earth contact or a fixed power cord with protective earth. Electrical appliances in protection class I can have parts with double or reinforced insulation, or parts which are operated with safety extra-low voltage.



**Indoor use**

Appliances with this symbol are intended solely for indoor use.



Food-safe surface



The Australian Regulatory Compliance Mark (RCM) is a single compliance mark used by suppliers after establishing compliance with all applicable regulations, including EMC, telecoms, radio comms, electromagnetic radiation (EMR) and electrical safety.



## Safety information

**IMPORTANT SAFETY INSTRUCTIONS – READ CAREFULLY AND KEEP FOR FUTURE REFERENCE!**

### Proper use

The microwave may only be used for heating up appropriate foodstuffs in microwave-suitable containers and dishes. It may not be used outside!

This appliance is designed for use in private households. The appliance is not designed for use in commercial, industrial areas or in laboratory environments.

- Please note that we shall not be liable in cases of improper use.
- Comply with all the information in these operating instructions, especially the safety information. Any other use is considered improper and can cause personal injury or property damage.

### Safety of children and persons



#### Risk of injury!

Risk of injury for children and people with reduced physical, sensory or mental capacity (for example, partially disabled people or older persons with impaired physical and mental capacity) or with a lack of experience and/or knowledge (for example, older children).

- Keep the appliance and its accessories out of the reach of children.
- This appliance can be used by children 8 years and older, and by people with reduced physical, sensory or mental capacity, or with a lack of experience and/or knowledge, but only with proper supervision, or if they have been instructed about how to use the appliance safely, and have understood the risks involved.

- Children must not be allowed to play with the appliance.
- Cleaning and user maintenance must not be carried out by children without supervision.
- Do not allow children less than 8 years of age near the appliance and its power cord, unless they are under constant supervision.



**DANGER!**

### **Risk of injury!**

Risk of choking and suffocation through swallowing or inhaling small parts or plastic wrap.

- Do not store any of the packaging material used (bags, polystyrene, etc.) within the reach of children.
- Do not allow children to play with the packaging material.



**WARNING!**

### **Warning – risk of electric shock!**

There is a risk of electric shock due to live parts.

- Before using for the first time and after each use, check the microwave and the power cord for damage.
- Do not use the microwave if the microwave or the power cord shows signs of damage.
- Make sure that the power cord is not damaged and does not run underneath the microwave or across hot surfaces or sharp edges.
- Unwind the power cord completely.
- Do not kink or pinch the power cord.
- Contact the Service Centre without delay if the appliance has been damaged during transport.
- Only connect the appliance to a properly installed earthed power point that complies with electrical safety requirements.

The supply voltage must match the technical specifications for the appliance.

- The power point must be readily accessible so that you can unplug the appliance from the power quickly if necessary.



### **Risk of injury!**

There is a risk of injury from microwave radiation.

- If the appliance is damaged, microwave radiation can escape through a leak. Damage to the power cord can cause an electric shock.
- If there is damage to the housing, covers, door to the cooking compartment or the door-closing mechanism, do not use the microwave under any circumstances. If this happens, turn the safety power point off immediately and pull the power cord out by the plug. Do not operate the microwave again until it has been repaired by a person trained to do so.
- **WARNING!** It is dangerous for all other people apart from a specially trained person to carry out any service or repair work requiring the removal of a cover that provides protection against radiation exposure from microwave energy.
- Do not, under any circumstances, make any unauthorised modifications to the appliance or try to open a component and/or repair it yourself. Only have your microwave and power cord repaired by a suitably qualified workshop, or contact Customer Service in order to avoid hazards.
- Do not remove any covers in the interior compartment of the microwave or the film on the inside of the viewing window, as microwave radiation can otherwise escape.
- Only use replacement parts or accessories that we have supplied or approved.

The microwave must not be immersed in water or other liquids, held under running water or used in damp rooms because this can result in an electric shock.

- Switch the microwave off at the power point and pull out the plug:
  - when cleaning the appliance,
  - if it is unsupervised,
  - if the appliance is no longer in use.
- Protect the microwave from dripping or splashing water. Avoid contact with water or other liquids. Keep the appliance, the power cord and the plug away from basins, sinks or similar. If liquid does get into the appliance, switch off the safety power point immediately and pull the plug out. Have the appliance checked by a suitably qualified workshop.
- Never touch the appliance or the power cord with wet hands.



**DANGER!**

### **Risk of explosion!**

There is a risk of explosion when operating the appliance in potentially explosive environments.

- Do not use the appliance in areas where there is a risk of explosion. This includes, for example, fuel pumps, fuel storage areas or areas in which corrosive agents are processed. This appliance should also not be used in areas where the air is contaminated with particles (e.g. flour or sawdust).

**NOTICE!**

### **Possible damage to property!**

There is a risk that the appliance may be damaged if not set up correctly.

- Place the microwave on a level, stable surface that can bear the weight of the appliance itself plus the maximum weight of the quantity of food prepared in it.
- Only use the appliance indoors.
- Do not expose the appliance to extreme conditions. Avoid:
  - high humidity or wet conditions,
  - extremely high or low temperatures,
  - direct sunlight,
  - open flame.
- Do not set the microwave up near heat sources.

Chemical additives in furniture coatings can damage the material of the appliance feet and leave residues on the surface of the furniture.

- If necessary, place the appliance on a heat-resistant underlay.

## Hot surfaces



### Risk of explosion!

When water is mixed with oil, it can ignite or even explode.

- Do not heat any mixtures of water and oil or fat in the microwave.
- Do not defrost any frozen fat or oil in the microwave.



### Risk of injury!

The appliance and its accessible parts become hot during use. There is a risk of injury from hot surfaces.

- Do not touch the housing.
- Avoid touching the heating elements inside the oven.

- Do not allow children less than 8 years of age near the appliance unless they are under constant supervision.
- In combination mode or grilling mode, children may only use the appliance under adult supervision due to high temperatures.
- The turntable becomes very hot after cooking with the grill! Always use oven mitts or heat-resistant gloves when you remove the turntable from the cooking compartment.



### **Risk of fire!**

There is a risk of fire if very high temperatures/hot appliance surfaces are not handled correctly.

- Do not place objects on top of the microwave. Ensure clearance of 30 cm above and 20 cm on either side of the appliance for adequate ventilation. The surface on which the appliance is placed should be at a minimum height of 85 cm (see **fig. C**). Do not cover or block the openings on the appliance.
- The appliance must be placed with its back wall against a wall.
- The microwave is designed as a free-standing appliance. Do not operate it in a built-in cabinet or a cupboard.
- Never leave the appliance unattended while it is in use.
- The microwave is not designed to be operated with an external timer switch or a separate remote control system.
- When heating or cooking foods in flammable materials such as plastic or paper containers, check on the microwave frequently due to the possibility of ignition.
- The microwave may only be used to heat food suitable for the microwave in suitable containers and dishes.
- Do not use baking paper in grill or combination mode.
- The microwave is designed to heat food and drinks. Drying food or clothing and heating heat packs, slippers, sponges,

damp cleaning cloths or similar can result in injuries, ignition or fire.

- Do not cook any dishes containing alcohol. Do not deep-fry or heat oil with the appliance.
- In order to avoid sparking, load the turntable evenly so that it does not touch the internal metal wall of the appliance during operation.
- If smoke develops, it is crucial to keep the oven door closed to prevent ignition or to smother any existing flames. Switch off the appliance immediately by turning off the power point and pulling out the plug.
- Only use the standard packs of popcorn labelled as being intended for preparation in the microwave.
- Never exceed the cooking times specified by the manufacturer.
- Do not store any food or other objects in the cooking compartment.

## Special safety instructions for handling microwaves



### **Risk of injury!**

There is a risk of injury from containers bursting.

- Do not heat any foods or liquids in firmly sealed containers. They may explode in the appliance or result in injuries when opened. Always remove the lids of sealable containers, such as e.g. baby bottles.



### **Risk of injury!**

There is a risk of injury from burns.

- Foods prepared in the microwave may heat unevenly. Test the temperature of the heated food before consuming. When heating baby food and baby bottles, always stir or shake the infant food to avoid burns.
- Do not cook eggs in their shells or heat whole hard-boiled eggs in the microwave, as they may explode while cooking and also after they are taken out. Only cook eggs in microwave dishes designed for that purpose.
- Prick food items with sealed skins, such as tomatoes, sausages, eggplant or the like, before cooking in order to prevent them from bursting.
- When cooking containers are opened (e.g. bags of popcorn, containers with lids) hot steam will escape. Always keep the opening away from your body when you open the container.
- When the cooking compartment is opened, hot steam will escape. Keep your distance.
- During the cooking cycle, the surfaces of the microwave, the accessories and the cooking dish become very hot. Use oven mitts. Allow the items to cool before you clean them.

### **NOTICE!**

### **Possible damage to property!**

There is a risk that the appliance will be damaged if it is handled incorrectly.

- Never operate the appliance without the turntable or without food in the cooking compartment.
- Only use the accessories provided or those described as suitable in these operating instructions.



- Never use dishes with metal decoration or metal dishes in the microwave because sparking can result in damage to the appliance or to the dish.
- Use microwave-safe dishes. When buying dishes, look for labels such as 'microwave safe' or 'for microwave use'.
- Do not move the appliance when it is in use.

## Safety instructions for heating liquids



### Risk of injury!

There is a risk of injury from burns.

- When heating liquids in the microwave, so-called boiling delay can occur, meaning that the liquid is already at boiling temperature without the typical bubbles occurring. If shaken, e.g. when being taken out of the microwave, the liquid can suddenly boil up. Liquid may suddenly spurt out.
- Do not use tall, narrow containers.
- When heating, place a glass or ceramic rod in the container to prevent delayed boiling up of the liquid. Wait briefly after heating, tap the container cautiously and stir the liquid before removing the container from the cooking compartment.

## Cleaning and caring for the appliance

### NOTICE!

### Possible damage to property!

There is a risk that the appliance will be damaged if it is handled incorrectly.

- Incorrect use of cleaning products on the appliance can result in the surfaces becoming damaged. Do not use aggressive

chemical cleaning products, abrasive cleaners or hard scourers/sponges.

- The appliance must not be cleaned with a steam cleaner. Steam can penetrate the interior of the appliance and damage the electronics and surfaces.
- Failure to clean the microwave adequately can result in the surface being destroyed, which in turn affects its useful life and may possibly result in dangerous situations.
- Clean the appliance regularly and remove food residues.
- When cleaning the cooking compartment and adjacent parts, observe the cleaning instructions. See “Cleaning and care” on page 39.

## About microwaves

Microwaves are high-frequency electromagnetic waves that cause your food to heat up in the cooking compartment. Microwaves heat all non-metal objects. For this reason, do not use any metal objects when operating the microwave. The more water is contained in the food, the better the heating works.

In order to achieve ideal heat distribution, leave meals in the microwave for one or two minutes after you have finished heating them to allow them to continue to cook.

### The effect of microwaves on food

- Microwaves penetrate the food to a depth of around 3 cm.
- They heat the water, fat and sugar molecules (foods with a high water content are heated most intensely).
- This heat then slowly penetrates the entire meal and results in the defrosting, heating and cooking of the food.
- The cooking compartment and the air in the cooking compartment are not heated (the food container is heated mainly through the hot food).
- All food requires a certain amount of energy for cooking or defrosting – according to the rule of thumb: High power – short time or low power – long time.

### The microwave appliance

- A microwave generator known as the magnetron produces the microwaves and directs them into the cooking compartment.
- The cooking compartment walls and viewing window reflect the microwaves so that they cannot escape from the cooking compartment.
- The microwave power and the cooking time can be set in several steps.
- After the time has elapsed or when the microwave door is opened, the magnetron switches off immediately.

## Cooking with the microwave

- In order to arrange the food correctly for cooking, place the thickest pieces on the outside edge.
- Follow the exact cooking time.
- Select the shortest cooking time specified and extend it if necessary.



### **Risk of fire due to very high temperatures.**

Very overcooked food can produce smoke or can ignite.

- Always supervise the cooking process.
  - Cover foods with a microwave-safe cover during the cooking cycle. Covering the food avoids spattering; the food is also cooked more evenly.
  - Meals such as pieces of chicken and rissoles should be turned once during preparation in the microwave to speed up cooking. Larger pieces such as roasts or roast chicken must be turned at least once.
  - It is also important to rearrange food, e.g. in the case of meat balls. After half the preparation time, the items should be rearranged from the top to the bottom and from the centre to outside.
  - Mix the food through if possible after heating in order to distribute the heat evenly, or leave it to continue to cook for a brief period.
  - When preparing microwave popcorn, put the popcorn package on a microwave-safe dish and place it on the turntable. Then proceed according to the microwave popcorn manufacturer's instructions.

## **Microwave-safe materials**

You can buy special dishes and accessories for your microwave. Look for labels such as 'microwave safe' or 'for microwave use'. However, you can also use your existing dishes if they are made of suitable material.

### **Suitable material**

- china, glass ceramic and heat-resistant glass
- plastic that is heat resistant and microwave safe (note: plastic can still be discoloured by food or deformed by heat)
- baking paper.

**NOTICE!****Risk of damage to property!**

Unsuitable materials can break or be deformed/scorched due to the high temperature.

- Do not use china, ceramic or plastic containers or foil covering when using the grill/grill combination mode.

**Overview of suitable materials**

The list that follows is a general guide intended to help you select the right cookware:

| Cookware                         | Microwave           | Grill | Hot air | Combination mode    |
|----------------------------------|---------------------|-------|---------|---------------------|
| Heat-resistant glass             | Yes                 | Yes   | Yes     | Yes                 |
| Non-heat-resistant glass         | No                  | No    | No      | No                  |
| Heat-resistant ceramic           | Yes                 | Yes   | Yes     | Yes                 |
| Microwave-safe plastic dishes    | Yes                 | No    | No      | No                  |
| Baking paper                     | Yes                 | No    | No      | No                  |
| Metal inserts                    | No                  | Yes   | Yes     | No                  |
| Grilling rack, included          | No                  | Yes   | Yes     | No                  |
| Aluminium foil, aluminium dishes | limited suitability | Yes   | Yes     | limited suitability |

\*Combination function: Microwave + grill or microwave and hot air.

## Size and shape of microwave-safe containers

Flat, wide containers are better than narrow, tall ones. 'Flat' foods can cook through more evenly.

Round or oval containers are better than square ones. There is a risk of localised overheating in the corners of square containers.

## Materials of limited suitability

- Earthenware and ceramics. Only use earthenware containers for defrosting and for short cooking times, since cracks may form in the earthenware due to the air and water content.
- Only use dishes with gold or silver decoration if the manufacturer labels them 'microwave-safe'.
- Do not use large amounts of aluminium foil. However, it can be used in small pieces to cover delicate parts. Also cover the corners of containers to prevent boiling over because the microwave energy is mainly concentrated in the corners. Keep a distance of 2.5 cm between the foil and the internal wall.
- Aluminium trays (e.g. for instant meals) may be suitable but must be at least 3 cm tall to be used in the microwave.

## Unsuitable materials

- Metal, that is, all metal saucepans, metal frying pans and metal lids.

### NOTICE!

## Risk of damage to property!

There is a risk that the appliance will be damaged if it is handled incorrectly.

- Never use dishes with metal decoration, metal dishes or grilling racks in the microwave because sparking can result in damage to the appliance or to the dish.
- Do not use crystal or lead crystal glass in the microwave. It can shatter, and coloured glass can discolour.
- Do not use any materials that are not heat resistant. They can deform or even burn.



In order to test whether a dish is suitable for use in the microwave, pour some water into the container and then put it into the microwave.

Press the  **17** button twice. The appliance will now run the microwave function for 1 minute. If you notice that the container is hotter than the food, it is not suitable for the microwave. Microwave-safe dishes are only heated by the heat of the food.



**WARNING!**

### **Risk of fire!**

There is a risk of fire if the appliance is handled incorrectly.

- If you notice sparks, flashes or even fire, immediately press the  **16** button, turn off the power point and pull out the plug.

## **Package contents**



**DANGER!**

### **Risk of choking and suffocation!**

Risk of choking and suffocation through swallowing or inhaling small parts or plastic wrap.

- Also keep the plastic packaging away from children.

After unpacking the microwave, make sure that the following parts have been included:

- MD 17500 microwave oven
- Turntable
- Grilling rack
- Operating instructions including guarantee documents

# Display



Displays time, duration of cooking program or weight

g

Displays weight in grams

°C

Displays temperature in Celsius



Child lock activated



Automatic program A-1 (Drinks) in progress



Automatic program A-2 (Pasta) in progress



Automatic program A-3 (Frozen pizza) in progress



Automatic program A-4 (Vegetables) in progress



Automatic program A-5 (Potatoes) in progress



Automatic program A-6 (Heating) in progress



Automatic program A-7 (Fresh pizza) in progress



Automatic program A-8 (Chicken) in progress



Automatic program A-9 (Potato gratin) in progress



Automatic program A-10 (Rissoles) in progress



Automatic program activated



Defrost mode



Grill/double grill mode



Hot air mode



Microwave mode



## Before first use



**DANGER!**

### **Risk of injury!**

There is a risk of injury from electric shock or microwave radiation. If the appliance is damaged, microwave radiation can escape through a leak. Damage to the power cord can cause an electric shock.

- If there is damage to the housing, covers, door, door seals or the door-closing mechanism, do not use the microwave under any circumstances. If this happens, turn the safety power point off immediately and pull the power cord out by the plug.
- Only allow your microwave and mains cord to be repaired by a suitably qualified workshop, or contact Medion Customer Service in order to avoid hazards.

**NOTICE!**

### **Risk of damage to property!**

There is a risk that the appliance will be damaged if it is not handled correctly.

- The cover **4** inside the cooking compartment must not be removed!
- Do not use the appliance outdoors.

## **Setting up the appliance**

Make sure that all packaging material has been removed from the appliance and the inside of the door.

## Before first use

---

- Do not place the microwave near sources of heat, in a location that is wet or very humid or near flammable materials.
- The feet must not be removed.
- Connect the microwave to a 230 V~50 Hz power point that is easy to reach and always readily accessible.







## Heating the empty appliance

Before using the microwave, the empty appliance must first be heated to allow any residues from manufacturing to evaporate. To do this, switch the appliance on without any food or accessories in it using hot air mode as described below:

- Open the door and remove any packaging or accessory parts from the cooking compartment.  
Then close the door again.

- Press the  **18** button several times until the display shows the  symbol.

The display will show **140°C**.

- Press the  **14** or  **15** buttons to select a cooking temperature of **230°C**.
- Press the  **17** button to confirm the setting.
- Press the  or  button to set a cooking time of 10 minutes.
- Press the  button again to start the heating cycle.



A slight odour may develop when heating the oven up for the first time. The vapour is harmless and will quickly dissipate. Ensure adequate ventilation, e.g. by opening a window.

The appliance will switch off automatically after 10 minutes. Wait until it has cooled down completely.

- Switch off the power point and pull out the plug, then clean the inside of the appliance once again with a damp cloth and dry the microwave carefully.

## Inserting the accessories

Once the empty microwave has been heated up as described above, it must not be operated again without the properly inserted turntable **2**.

- Insert the turntable **2**, centring it on the turntable shaft **9**.

## Operation

Every time a button is pressed, an alert tone will sound to confirm that a button has been pressed.



If after making settings no additional buttons are pressed to complete the process within about five minutes, the microwave will automatically switch to standby mode.

### Setting the time



If the microwave is being used for the first time or if the electricity supply has been interrupted, the display will show **12 0:00** and you will need to set the time.

- Press the  **18** button.



The hour display **00** will flash.

- Press the  **14** or  **15** buttons until the correct hour is shown on the display.
- Press the  **17** button to confirm the setting.

The minute display **00** will flash.

- Press the  or  buttons until the correct minute is shown on the display.
- Press the  button to confirm the setting.

### Setting the kitchen timer (countdown)

- Press the  **18** button twice.
- Press the  **14** or  **15** buttons to set the desired time in minutes and seconds (**0:00**).

The maximum cooking time you can set is 95 minutes.

- Press the  **17** button.

The countdown will start.

- Alert tones will sound after the set time has elapsed.
- To stop the countdown before the time has elapsed, press the  **16** button.

### Child safety lock

- Press the  **16** button and hold it down for 3 seconds. An alert tone will sound and the display will show a lock symbol.

The buttons on the microwave no longer perform any function.

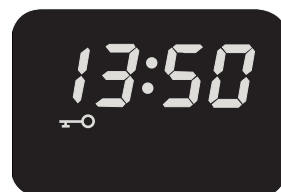





## Operation

- To deactivate the child safety lock, press and hold the button  again for 3 seconds, until you hear an alert tone.



The child safety lock symbol will disappear.

## Cooking with microwave energy

- To cook using microwave energy, press the  **18** button several times until the  symbol is shown on the display.
- The display will show power level **P100**.
- Press the  **14** or  **15** buttons to select a power level according to the following table:



| Display shows | Power (watts) |
|---------------|---------------|
| <b>P100</b>   | 900 W         |
| <b>P90</b>    | 810 W         |
| <b>P80</b>    | 720 W         |
| <b>P70</b>    | 630 W         |
| <b>P60</b>    | 540 W         |
| <b>P50</b>    | 450 W         |
| <b>P40</b>    | 360 W         |
| <b>P30</b>    | 270 W         |
| <b>P20</b>    | 180 W         |
| <b>P10</b>    | 90 W          |
| <b>P00</b>    | 0 W           |

- Press the  **17** button to confirm the setting.
- Press the  or  buttons to set the desired cooking time in the following time intervals. The maximum cooking time is 95 minutes.

|                            |                        |
|----------------------------|------------------------|
| From 0 seconds to 1 minute | in 5-second intervals  |
| From 1 to 5 minutes        | in 10-second intervals |
| From 5 to 10 minutes       | in 30-second intervals |
| From 10 to 30 minutes      | in 1-minute intervals  |
| From 30 minutes            | in 5-minute intervals  |

- Press the  button to confirm the setting.

The cooking cycle will start.

## End of the cooking cycle

At the end of every cooking cycle, alert tones will sound and the display will show the time again. The cooking cycle is complete.





## Risk of injury!

The food and containers may become very hot. There is a risk of burns.

- Always use oven mitts or heat-resistant gloves when you remove the food from the cooking compartment.

## Interrupt the program

It is often necessary to interrupt the cooking program, for example, to turn or stir the food after half of the cooking time has elapsed.



- Open the door or press the  **16** button in order to interrupt the program. The remaining cooking time will still be shown on the display.
- After you have shut the door again, press the  button to continue the cooking cycle.
- Press the  button twice to completely cancel the program early.

## Quick start

When you press the  **17** button without having previously set a power level, the cooking program is started using the microwave mode at the highest power level (900 watts).



- In order to increase the cooking time, press the  button a number of times in rapid succession:  
press 1 x: 0:30 minutes;  
press 2 x: 1:00 minutes;  
press 3 x: 1:30 minutes;  
press 4 x: 2:00 minutes  
etc. to a maximum of 95 minutes.

The cooking program will begin automatically a short time after the last button press.







- Alternatively, you can press the  **14** or  **15** buttons in standby mode (time is displayed) to set the desired cooking time and then press the  button.

## Automatic defrosting by weight or time

The defrosting time and power level are set automatically as soon as you have entered the weight of the food to be defrosted. The weight range for frozen food is 100 g to 2000 g.

- Press the  **18** button several times until the  and  symbols are shown on the display.

The display will show **DEF1** (see adjacent image).

- Press the  **14** or  **15** buttons to select defrosting by weight (**DEF1**) or by time (**DEF2**).
- Press the  **17** button to confirm the setting.
- Press the  or  buttons to set the desired weight in grams or the defrosting time in minutes.
- Press the  button to start defrosting.



Whenever possible, turn the food over after half the time has elapsed to optimise the defrosting (see “Interrupt the program” on page 29).

Then press the  button again to resume the program.

## Grill or combination mode

The grilling function is particularly useful for thin cuts of meat, steaks, minced meat, kebabs, sausages or chicken pieces. It is also suited for toasting open sandwiches and gratin dishes.

When using the grill function, you can use the supplied grilling rack **11** for suitable foods. Do not use the grilling rack without the turntable **2**.

The longest grilling time is 95 minutes.





The appliance allows you to combine the different variations of the combination function. These all employ several modes at the same time, such as microwave and grill, or microwave, grill and hot air.

The maximum cooking time for each of the programs is 95 minutes.

### NOTICE!

## Risk of damage to property!

There is a risk of damage to the appliance from overheating.







- Observe the minimum requirements of the appliance for clearance from the wall and do not cover the ventilation slots under any circumstances.
- Press the  **18** button several times until the display shows the  symbol.
- The display will show **G-1**.
- Press the  **14** or  **15** buttons to select the desired mode or the desired combination mode (see table below).

| Display shows | Mode      |           |              |         |
|---------------|-----------|-----------|--------------|---------|
|               | Microwave | Top grill | Bottom grill | Hot air |
| <b>G-1</b>    |           | *         |              |         |
| <b>G-2</b>    |           | *         | *            |         |
| <b>G-3</b>    |           |           | *            |         |
| <b>C-1</b>    | *         | *         |              |         |
| <b>C-2</b>    | *         | *         |              |         |
| <b>C-3</b>    | *         | *         | *            |         |
| <b>C-4</b>    | *         | *         | *            |         |
| <b>C-5</b>    | *         | *         |              | *       |

- Press the  **17** button to confirm the setting.



#### For program C-5:

- Press the  or  button to enter the cooking temperature.
- Press the  button to confirm the setting.
- Press the  or  button to enter the cooking time.
- Press the  button to confirm the setting.

The appliance will start the cooking cycle.



After half the time has elapsed, an alert tone will sound. Where appropriate, open the door and turn the food over to optimise cooking (see “Interrupt the program” on page 29). Then press the  button again to resume the program.

## Hot air

In hot air mode, hot air circulates inside the compartment. Hot air is particularly recommended for preparing casseroles or crispy dishes.



To cook with hot air, proceed as follows:

- Press the  **18** button several times until the display shows the  symbol.



## Operation

---

The display will show **140°C**.



- Press the  **14** or  **15** buttons to select the desired cooking temperature.

You can set temperatures between **140°C** and **230°C**.

- Press the  **17** button to confirm the setting.
- If you wish to preheat the appliance, press the  button again.

After the set temperature is reached, an alert tone will sound.

If you do not wish to preheat the appliance, please proceed to the next step.

- Press the  or  button to enter the cooking time. The maximum cooking time is 95 minutes.
- Press the  button.

The appliance will start the cooking cycle.



## Using several programs

The appliance can run several cooking programs one after the other; this does not include the auto programs, however. Up to 3 sequences are possible, which run automatically.

Set each of the cooking programs as described, and press the  **17** button after setting the last cooking program.

### For example:

You want to defrost food with the defrost program, then start the grill program and then start a second grill program.

- Set the defrost program as described on Page 30 without pressing the  button at the end.
- Then set the grill program as described from Page 30.
- Now press the  button to start the program.

## Automatic cooking

For automatic cooking, it is not necessary to enter the cooking time and power level. The microwave automatically determines the settings, depending on what food and weight are selected.

The table provides an overview of the automatic programs, what is shown on the display and which mode is active.



| Display shows | Program       | Modes     |                  |         |
|---------------|---------------|-----------|------------------|---------|
|               |               | Microwave | Top/bottom grill | Hot air |
| <b>A-1</b>    | Drinks        | *         |                  |         |
| <b>A-2</b>    | Pasta         | *         |                  |         |
| <b>A-3</b>    | Frozen pizza  | *         | *                |         |
| <b>A-4</b>    | Vegetables    | *         |                  |         |
| <b>A-5</b>    | Potatoes      | *         |                  |         |
| <b>A-6</b>    | Reheat        | *         |                  |         |
| <b>A-7</b>    | Fresh pizza   | *         | *                |         |
| <b>A-8</b>    | Chicken       | *         | *                |         |
| <b>A-9</b>    | Potato gratin | *         |                  | *       |
| <b>A-10</b>   | Rissoles      | *         |                  | *       |

### Setting the auto program



**WARNING!**

#### Risk of fire!

There is a risk of fire if flammable materials are used.

- For programs that use the grill or hot air mode, do not under any circumstances use covers or dishes that are not heat resistant because they may melt or catch fire!



**WARNING!**

#### Risk of injury!

The turntable is very hot after cooking with the grill. There is a risk of burns.

- Always use oven mitts or heat-resistant gloves when you remove the turntable from the cooking compartment.

## Operation

- In standby mode (time is displayed) press the **MENU** **13** button once or several times in order to set program **A-1** to **A-10**.

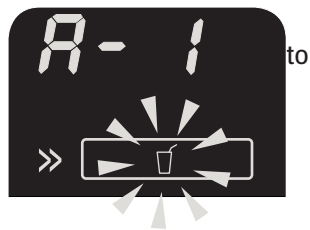

The display will show a program number (e.g. 'A-1' for auto program 1), the **A** symbol and the symbol for the cooking program selected.

Press the **◊** **17** button to confirm the setting.

- Press the **∧** **14** or **∨** **15** buttons to set the weight of the food/number of serves.

The weight/quantity is shown on the display. The quantities can be set according to the table:

| Program                           | Weight increments |        |        |        |       |
|-----------------------------------|-------------------|--------|--------|--------|-------|
| A-1<br>Drinks (200 ml serve)      | 1                 | 2      | 3      |        |       |
| A-2<br>Pasta                      | 100 g             | 200 g  | 300 g  |        |       |
| A-3<br>Frozen pizza               | 150 g             | 300 g  | 450 g  |        |       |
| A-4<br>Vegetables                 | 100 g             | 200 g  | 300 g  | 400 g  | 500 g |
| A-5<br>Potatoes<br>(200 g serve)  | 1                 | 2      | 3      |        |       |
| A-6<br>Reheat                     | 200 g             | 300 g  | 400 g  | 500 g  | 600 g |
| A-7<br>Fresh pizza                | 150 g             | 300 g  | 450 g  |        |       |
| A-8<br>Chicken                    | 800 g             | 1000 g | 1200 g | 1400 g |       |
| A-9<br>Potato gratin              | 1200 g            |        |        |        |       |
| A-10<br>Rissoles<br>(125 g serve) | 3                 | 4      | 5      |        |       |

Press the **◊** **17** button.

The appliance will start the cooking cycle.

If the meal is not cooked through properly, cook it again for a few more minutes with the microwave or grill program. Extending the cooking time in grill mode also means that the food browns more.



Please note that the size, shape and type of food influence the cooking results.



In hot air and grill modes and some automatic programs, the exhaust fan may keep running for a little while after the cooking cycle ends. This cools the appliance down faster. After the appliance has cooled down sufficiently, the exhaust fan switches off automatically.

### **Program A-1: Drinks**

This program uses the microwave function. Use a microwave-safe container for heating.

- Place the drink you would like to heat up on the turntable in the cooking compartment. If you place several containers in the microwave, make sure that they are not touching.
- Select setting 1, 2 or 3 depending on the volume of the drink.
- Start the program for drinks.

If the drink(s) are not hot enough, start another cooking cycle using the microwave function (as described from Page 28).

### **Program A-2: Pasta**

This program uses the microwave function.

Use a tall container for cooking pasta because there is a risk of boiling over. Use as much water as you would for conventional cooking.

- Place the container with the pasta in the centre of the turntable in the cooking compartment.
- Select the 100 g, 200 g or 300 g setting, depending on the quantity of pasta.
- Start the program for pasta.

If the pasta is still too hard after cooking, start another cooking cycle using the microwave function (as described from Page 28).

### **Program A-3: Frozen pizza**

This program uses the microwave and grill function. Use heat-resistant, microwave-safe dishes or place the pizza directly onto the turntable.

- Select the 150 g, 300 g or 450 g setting, depending on the weight of the pizza.
- Start the program for frozen pizza.

If the pizza is not hot enough after defrosting and heating, start another cooking cycle using the microwave function (as described from Page 28).

### **Program A-4: Vegetables**

This program uses the microwave function. Use a microwave-safe container for heating.

- Put the vegetables in the container with a little water.
- Place the container in the centre of the turntable.
- Select a setting between 100 g and 500 g, depending on the quantity of vegetables.
- Start the program for vegetables.

If the vegetables are still underdone after cooking, start another cooking process using the microwave function (as described from Page 28).

### **Program A-5: Potatoes**

This program uses the microwave function. Use a microwave-safe container for heating. We recommend cooking unpeeled potatoes. Prick the skins a few times.

- Put the unpeeled potatoes into the container. It is best to use potatoes of a similar size. If possible, the potatoes should not be touching.
- Place the container in the centre of the turntable.
- Select setting 1, 2 or 3 depending on the number of potatoes (based on setting 1 for one 200 g potato).
- Start the program for potatoes.

If the potatoes are still underdone after cooking, start another cooking cycle using the microwave function (as described from Page 28).

## Program A-6: Reheat

This program uses the microwave function. Use a microwave-safe container for heating.

- Place the plate with the meal in the centre of the turntable.
- Select a setting between 200 g and 600 g depending on the size of the meal.
- Start the reheating program.

If the meal is not hot enough after heating, start another cooking cycle using the microwave function (as described from Page 28).

## Program A-7: Fresh pizza from the refrigerated section

This program uses the microwave and grill function. Use heat-resistant, microwave-safe dishes or place the pizza directly onto the turntable.

- Select the 150 g, 300 g or 450 g setting, depending on the weight of the pizza.
- Start the program for fresh pizza.

If the pizza is underdone after baking, start another cooking cycle using combination mode C-3 Microwave + Double Grill (as described from Page 30).

## Program A-8: Chicken

This program uses the microwave and grill function. Use heat-resistant, microwave-safe dishes.

- Place the poultry on a dish that is suitable for grill mode. Season the chicken as required. Place the dish in the centre of the turntable.
- Select the 800 g, 1000 g, 1200 g or 1400 g setting, depending on the weight of the chicken.
- Start the program for chicken.
- The poultry must be turned in order to cook evenly. An alert tone sounds after around 2/3 of the time for this purpose. Turn the poultry over and press the  button in order to resume the program.

If the chicken is still underdone or not brown enough after the program, start another cooking cycle using combination mode C-4 Microwave + Double Grill (as described from Page 30).

### **Program A-9: Potato gratin**

This program uses the microwave and hot air function. Use a heat-resistant, microwave-safe dish.

- Place the dish with the food in the centre of the turntable.
- Confirm a quantity of 1200 g.
- Start the program for potato gratin.

If the potato gratin is still underdone or not brown enough after the program, start another cooking cycle using the grill or microwave function (as described from Page 30).

### **Program A-10: Rissoles**

This program uses the microwave and hot air function. Use heat-resistant, microwave-safe dishes.

- Place the rissoles on a plate that is suitable for hot air mode. Place the dish in the centre of the turntable.
- Select setting 3, 4 or 5 depending on the weight of the rissoles (based on a weight of 125 g for each rissole).
- Start the program for rissoles.

If the rissoles are still underdone after the program, start another cooking cycle using the grill or microwave function (as described on Page 30 and Page 28).

## Cleaning and care



**WARNING!**

### **Risk of electric shock!**

There is a risk of electric shock from live wires.

- Turn the microwave off, then turn the power point off and pull out the plug before you clean the appliance.



**WARNING!**

### **Risk of short circuit!**

Water splashes and/or steam can cause a short circuit.

- Do not under any circumstances use a steam cleaner to clean the appliance.

**NOTICE!**

### **Possible damage to property!**

Incorrect use of cleaning products on the microwave can result in the surfaces becoming damaged.

- Do not use aggressive chemical cleaning products, abrasive cleaners or hard scourers/sponges.

Failure to keep the appliance properly clean can result in the destruction of the appliance surface, which in turn affects its useful life and may result in dangerous situations. For this reason, clean the microwave regularly and remove all food residues.

- Always keep the microwave clean inside. Use a damp cloth to wipe off spatters or spilt liquids adhering to the walls of the cooking compartment. If there is heavy soiling, a mild cleaning agent can be used. Do not use aggressive, abrasive cleaners or sharp metal scrapers to clean the viewing window **1** of the appliance door because they can scratch the surface and destroy the glass.

## Storage

---

- Outer surfaces should be cleaned with a damp cloth. In order to prevent damage to the operating parts inside the microwave, do not allow water to enter the air vents.
- Clean components of the door, viewing window and the closing mechanism **8** carefully with a mild soap solution. Take particular care not to damage these parts.
- Do not use a steam cleaner. It could damage the surfaces.
- Make sure the control panel does not get wet. Clean it with a soft, damp cloth. Leave the door of the microwave open when you clean the control panel in order to prevent the appliance from being turned on by mistake.
- If the appliance is operated in a very humid environment, condensation can occur on the outer surfaces. If condensation collects on the inside or outside surfaces, wipe it off with a soft cloth.
- The turntable **2** must be taken out from time to time in order to clean it. Wash the turntable in warm water and a mild soap solution or in the dishwasher.
- Afterwards, dry the turntable thoroughly with a soft cloth.
- Wash the grilling rack **11** in warm water and a mild soap solution. Soak stubborn soiling for a while.
- Wipe the cooking compartment out with a damp cloth and a mild cleaning agent.
- Lingering odours in the microwave can be eliminated by placing a cup of water with the juice and rind of a lemon into a tall, microwave-safe container and heating it for 5 minutes in the microwave. Wipe out thoroughly and wipe dry with a soft cloth.
- If the light **5** in the microwave needs to be replaced, contact a suitably qualified workshop or Customer Service.

## Storage

When the cooking cycle has finished and the display shows the time **12**, open the door and take the cooked food out. The appliance will switch to standby at the end of the cooking cycle.

- If you do not plan to use the microwave for a long period of time, switch off the power point and unplug the appliance. Store the microwave in a dry, dust-free location.



# Troubleshooting

| Problem                                  | Possible cause                                                                          | Solution                                                          |
|------------------------------------------|-----------------------------------------------------------------------------------------|-------------------------------------------------------------------|
| The appliance will not start.            | The appliance is not plugged in properly.                                               | – Pull out the plug, and plug it back in after around 10 seconds. |
|                                          | The integrated fuse in the microwave has blown or the safety switch has been activated. | – Contact the Service Centre.                                     |
| The appliance will not start.            | The power point is faulty.                                                              | – Check the power point by plugging in another appliance.         |
| The appliance does not heat.             | The door is not closed.                                                                 | – Close the door.                                                 |
| The turntable <b>2</b> is making noises. | The rollers are dirty.                                                                  | – Clean the turntable.                                            |
|                                          | The turntable is not correctly inserted.                                                | – Insert the turntable correctly.                                 |

## Disposal

### Packaging



The device has been packaged to protect it from damage in transit. The packaging is made of materials that can be recycled in an environmentally friendly manner.

### Device



At the end of its service life, do not dispose of the device in the normal household rubbish. Instead, contact your local authority to find out how to dispose of the device in an environmentally friendly manner.

## Technical specifications

Nominal voltage: 230-240V ~ 50 Hz

Microwave rated input: 1500 W

### Rated outputs

Upper grill: 1100 W

Lower grill: 500 W

Convection: 2300 W

Rated power output (microwave): 900 W

Microwave frequency: 2450 MHz

### Dimensions (W x H x D)

Appliance: 513 x 306 x 505 mm

Cooking compartment volume: 25 litres

Net weight: 18.5 kg



Cooking compartment and turntable are food safe.

## Declaration of Conformity

This product meets the requirements of Australian Standard AS/NZS CISPR 11. This product is classed as Group 2 Class B appliance in conformity with the relevant standard. Group 2 means that the appliance generates high-frequency energy in the form of electro-magnetic radiation for the heat treatment of food. Class B appliance means that the appliance is suitable for domestic use.

MEDION AG hereby declares that the Microwave oven MD 17500 conform to all relevant Australian requirements.

## Service information

Please contact our Customer Service team if your device ever stops working the way you want or expect it to. There are several ways for you to contact us:

- In our Service Community, you can meet other users, as well as our staff, and you can exchange your experiences and pass on your knowledge there. You will find our Service Community at <http://community.medion.com>.
- Alternatively, use our contact form at [www.medion.com/contact](http://www.medion.com/contact).
- You can also contact our Service team via our hotline or by post.

| Opening times                                                                      | Hotline number |
|------------------------------------------------------------------------------------|----------------|
| Mon – Fri:<br>08:30AM to 06:00PM EST                                               | ① 1300 884 987 |
| Service address                                                                    |                |
| <b>MEDION Australia Pty Ltd.</b><br><b>Chatswood, NSW 2067</b><br><b>Australia</b> |                |



You can download this and many other sets of operating instructions from our service portal at [www.medion.com/au/contact.php](http://www.medion.com/au/contact.php).

You will also find drivers and other software for a wide range of devices there.

You can also scan the QR code on the side of the screen, to download the operating instructions onto your mobile device from the service portal.

## Legal Notice

Copyright © 2019

Date: 12.03.2019

Version: V3.1

All rights reserved.

These operating instructions are protected by copyright.

Mechanical, electronic and any other forms of reproduction are prohibited without the written permission of the manufacturer.

Copyright is owned by the company:

**MEDION AG**

**Am Zehnthof 77**

**45307 Essen**

**Germany**

Please note that you cannot use the address above for returns. Please always contact our Customer Service team first.



**AMBIANO®**

**25 L MICROWAVE OVEN  
WITH GRILL & CONVECTION  
Warranty Details**

---

**REGISTER YOUR PURCHASE AT [www.aldi.com.au/en/about-aldi/product-registration/](http://www.aldi.com.au/en/about-aldi/product-registration/)  
TO KEEP UP-TO-DATE WITH IMPORTANT PRODUCT INFORMATION**



---

The product is guaranteed to be free from defects in workmanship and parts for a period of 36 months from the date of purchase. Defects that occur within this warranty period, under normal use and care, will be repaired, replaced or refunded at our discretion. The benefits conferred by this warranty are in addition to all rights and remedies in respect of the product that the consumer has under the Competition and Consumer Act 2010 and similar state and territory laws.

Our goods come with guarantees that cannot be excluded under the Australian Consumer Law. You are entitled to a replacement or refund for a major failure and for compensation for any other reasonably foreseeable loss or damage. You are also entitled to have the goods repaired or replaced if the goods fail to be of acceptable quality and the failure does not amount to a major failure.

---

**AFTER SALES SUPPORT**

  1300 884 987

 [www.medion.com.au](http://www.medion.com.au)

**3**  
YEARS  
WARRANTY



**AMBIANO®**

**25 L MICROWAVE OVEN  
WITH GRILL & CONVECTION  
Repair and Refurbished Goods  
or Parts Notice**

---

**REGISTER YOUR PURCHASE AT [www.aldi.com.au/en/about-aldi/product-registration/](http://www.aldi.com.au/en/about-aldi/product-registration/)  
TO KEEP UP-TO-DATE WITH IMPORTANT PRODUCT INFORMATION**

---

Unfortunately, from time to time, faulty products are manufactured which need to be returned to the Supplier for repair.

Please be aware that if your product is capable of retaining user-generated data (such as files stored on a computer hard drive, telephone numbers stored on a mobile telephone, songs stored on a portable media player, games saved on a games console or files stored on a USB memory stick) during the process of repair, some or all of your stored data may be lost.

**We recommend you save this data elsewhere prior to sending the product for repair.**

You should also be aware that rather than repairing goods, we may replace them with refurbished goods of the same type of use refurbished parts in the repair process.

**Please be assured though, refurbished parts or replacements are only used where they meet ALDI's stringent quality specifications.**

If at any time you feel your repair is being handled unsatisfactorily, you may escalate your complaint. Please telephone us on 1300 884 987 or write to us at:

**MEDION Australia Pty Ltd  
Chatswood, NSW 2067; Australia  
Hotline: 1300 884 987  
(Opening hours: Mon - Fri 08:30AM to 06:00PM EST)  
Internet [www.medion.com.au](http://www.medion.com.au);  
E-mail Support [australia@medion.com](mailto:australia@medion.com)**

---

**AFTER SALES SUPPORT**

  1300 884 987

 [www.medion.com.au](http://www.medion.com.au)



ALDI guarantees that our exclusive brand products are developed to our stringent quality specifications. If you are not entirely satisfied with this product, please return it to the nearest ALDI store within 60 days from the date of purchase, for a full refund or replacement, or take advantage of our after sales support by calling the supplier's Customer Service Hotline.



Made in China

AMBIANO is a registered trademark of ALDI Stores

DISTRIBUTED BY:

ALDI STORES

1 SARGENTS ROAD

MINCHINBURY NSW 2770

[www.aldi.com.au](http://www.aldi.com.au)

VERSION: V3.1

**AFTER SALES SUPPORT**

98194 The logo features the letters 'W2' in a bold, sans-serif font, with a small square icon to the right containing the number '2'.



**1 300 884 987**



**[www.medion.com.au](http://www.medion.com.au)**

MODEL:

MD 17500

06/2019

**3**

**YEARS  
WARRANTY**