

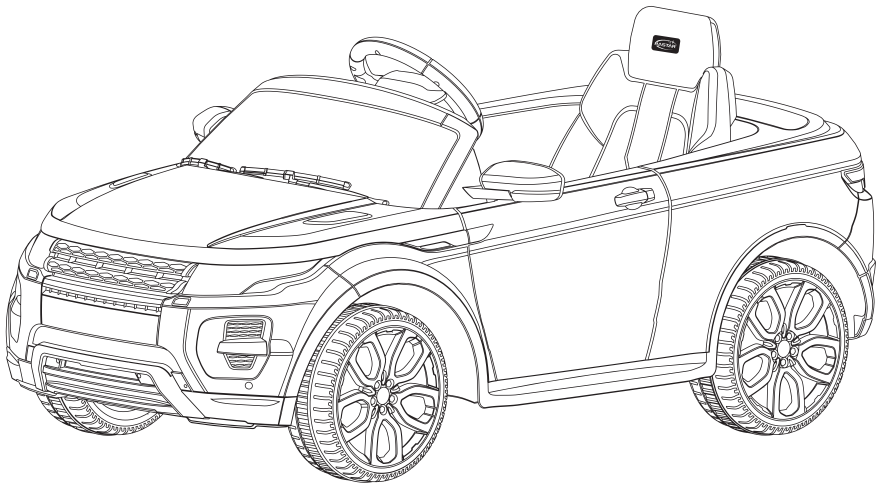

Rastar Baby

RANGE ROVER EVOQUE

Ride-on Instruction



The packing has to be kept since it contains important information.



WARNING:

CHOKING HAZARD-Small parts.
Not for children under 3 years.

CONTENTS

ABOUT "RASTAR BABY" PRODUCT	01
SPECIFICATION	02
PARTS	02
ASSEMBLY	04
REPLACE BATTERY OF TRANSMITTER AND STEERING WHEEL	06
NORMAL OPERATION	07
STORAGE BATTERY MAINTENANCE	07
OVERCURRENT PROTECTOR	08
OPERATING FUNCTION	08
WARNING	10
CARE AND MAINTENANCE	11
MALFUNCTION SHOOTING GUIDE	11
RIDE-ON ELECTRICAL ILLUSTRATION	12
MAINTENANCE	13

ABOUT "RASTAR BABY" PRODUCT

Thank you for purchasing our products. We have devoted ourselves to creating comfortable and safe electronic remote control toys, and creating a colorful childhood for your children.



It is very important to read this instruction carefully before usage. This instruction not only specifies assembly process and proper application method, but also help you to avoid injury or damaging the product in case of incorrect operation.



XINGHUI BABY SUPPLIES CO., LTD. reserves the right of the final explanation to all the pictures and descriptions contained in this manual. The manual is subject to change without separate notice. Please contact your local distributor or directly consult us if you have any questions.



This product can be operated in Battery operated/Radio control mode, together with forward, reverse, left, right, and equipped with functions like headlight, taillight, built-in music playing and MP3 input.

NO.	Style	Remark
81400	Radio control with painting	Both Radio control and Battery operated

SPECIFICATION

Size	(120x65.5x51.6)cm
For child	37months old - 96months old
Max.weight loaded	25kg
Net Weight	14.3kg
Power	Rechargeable
Speed	D1 (2-3)km/h D2 (3-4)km/h
Battery	6V 7Ah lead-acid / 6V 10Ah lead-acid/ 6V 12Ah lead-acid
Power supply	Input:AC220V 50Hz Output:DC6V 500mA
Charging period	Charged for (10-15)h/time Run for (1-1.5)h
Rechargeable times	More than 300
For temperature	5-35 Celsius degree
Power of Motor	DC6V 25W

PARTS

Please read carefully before assembly.

NO.	Desc.	Qty	NO.	Desc.	Qty
1	Steering Wheel	1	12	Transmitter	1
2	Windshield	1	13	Lubricant	1
3	Seat	1	14	Key	2
4	Screw	5	15	MP3 Input line	1
5	Protector	5	16	Car Body	1
6	Storage Battery	1	17	Wheel Core	9
7	Battery Locker	1	18	Gasket	8
8	Battery Cover	1	19	Clip	5
9	Screw Pin	1	20	Wheel	4
10	Hexnut	1	21	Rim Cover	4
11	Charger	1	22	Instruction	1

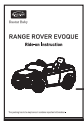
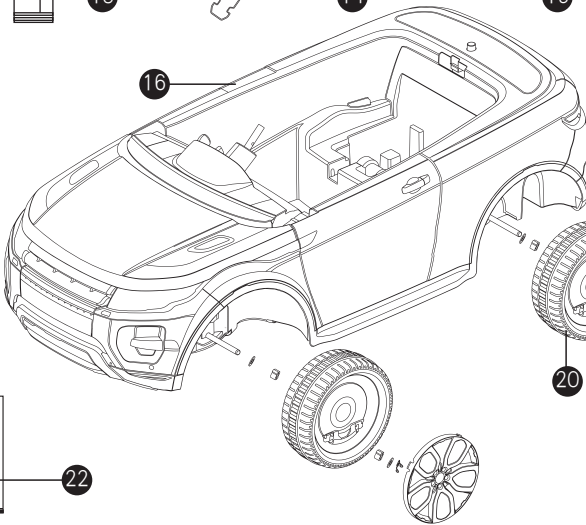
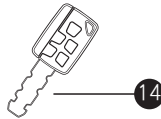
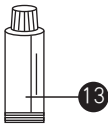
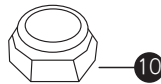
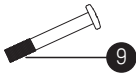
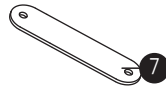
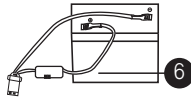
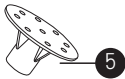
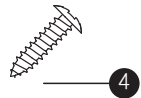
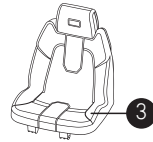
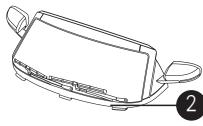
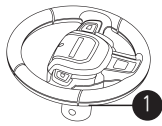

The serial number of all spare parts showed as “(NO.)” in the following descriptions.



If the quantity and shape of some spare parts in this manual are different from that of products you buy, it might be because some parts of the car you buy already have been installed or because we reduce setup steps and quantities of spare parts for making the installing easier. Please check and review.

ASSEMBLY

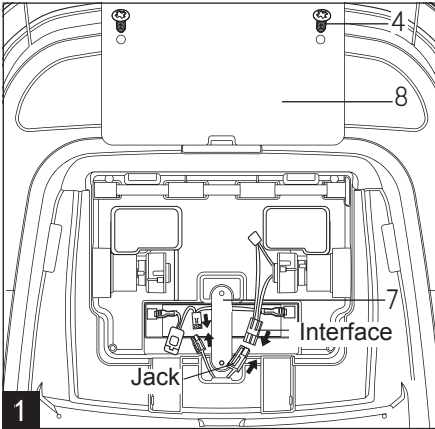

1. Install battery and power supply

- Put the storage battery into the battery compartment. Plug the interface to the jack, connect the red terminal and the black terminal respectively to the anode and cathode of battery. (Notice: make sure they are correctly connected, red to red, black to black, otherwise, it will cause short-circuit.)
 - Install the battery locker(7) to the designated position, and fix it with 2 screws(4)
 - Install the battery cover(8) to the designated position, and fix it with 2 screws(4)
- ★ Replace or take out the storage battery and power.
Loosen the 2 screws(4) on battery cover(8)
Unplug the interface and jack, loosen the 2 screws(4) on battery locker(7), then the storage battery can be taken out.

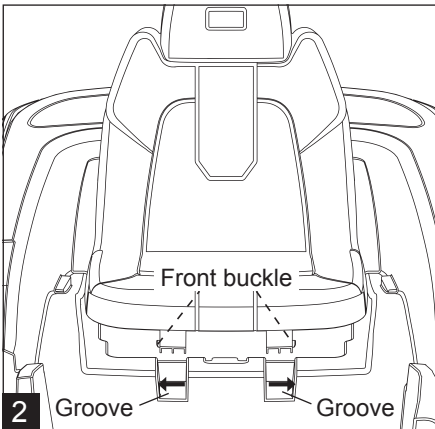

2. Install seat

- Put the seat (3) to the designated position, fix the front buckles of seat to the grooves of car body.
 - Press down the button behind the seat and lay down the seat, then release the button and the seat will be locked. To unlock the seat, press down the button and raise the seat.
- Notice: This seat is equipped with seat belt, which is only a decoration to develop the safety sense of children, it can not provide any substantial protection.

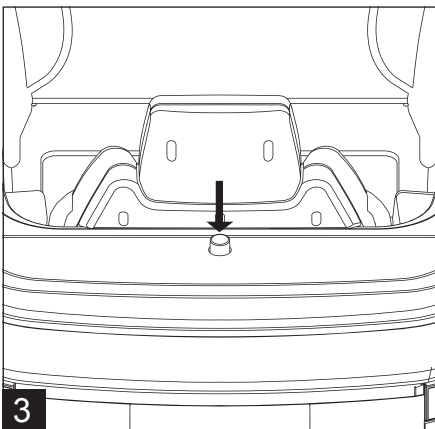

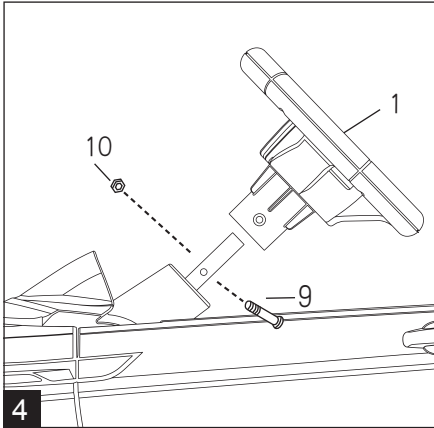

3. Install steering wheel

- Remove the protector (5) at the upside of the axes, which is non-functional but only for protecting use during the transportation. Please dispose properly.
- Please install the steering wheel (1) to the specific place and use Screw (9) and Hexnut (10) to screw it tightly after you make sure the steering wheel is in the right place. Please see picture 4.

4. Install windshield

- Install windshield(2) to the designated position, See picture 6.
 - Push the buckles of windshield to fix the windshield.
- Note: firstly you can install one end of the headrest, then install the other end.

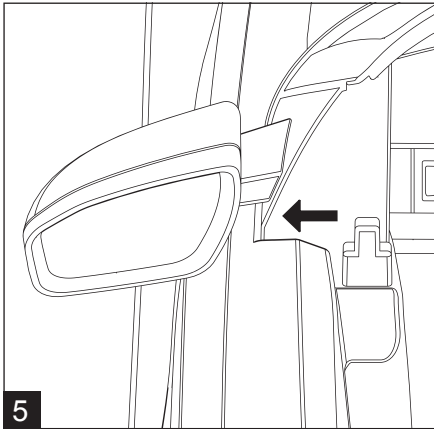

5. Assembly completed

6. Schematic diagram of assembly and disassembly

- Picture 7 is schematic diagram of assembly, disassembly and maintenance. Please pay attention to the sequence of spare parts install and take good care of them after disassembly.

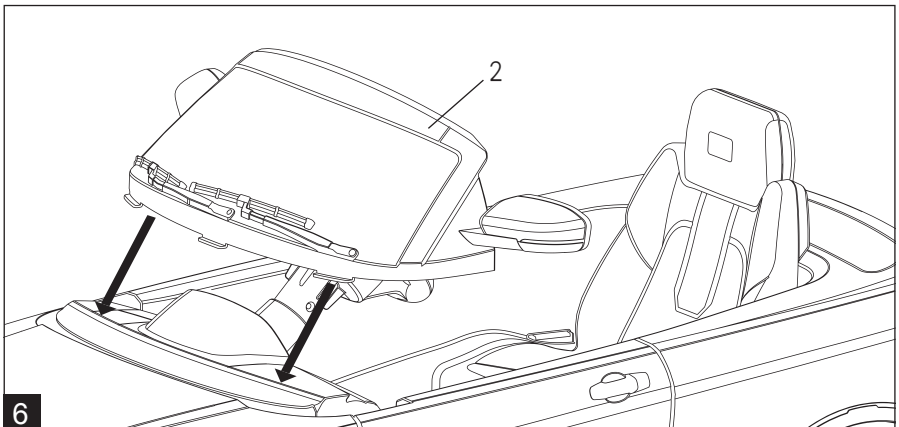

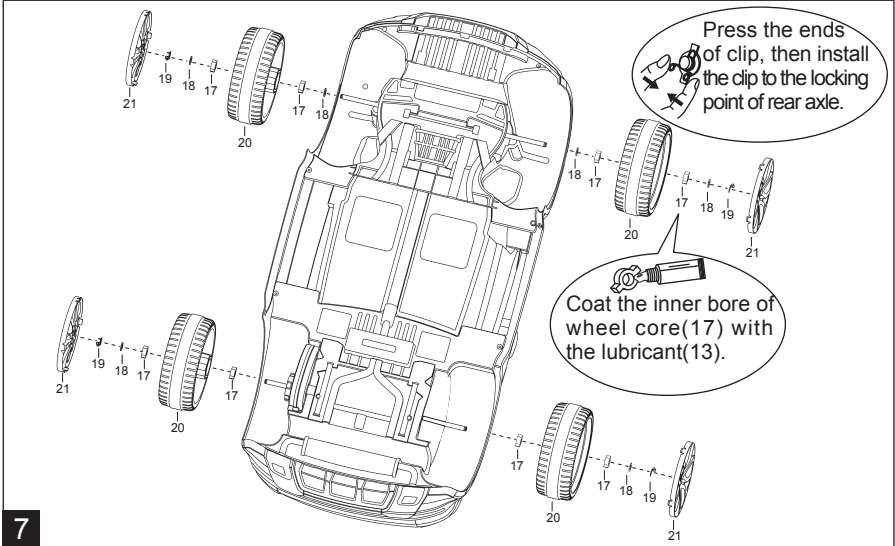

7

Replace battery of transmitter and steering wheel

1. Replace battery of transmitter

- Put the antenna into the controller socket. Open the lid and put the 9V battery according to its polarity, then close the lid.

2. Replace battery of steering wheel

- Please take down the battery cover according to the indicating arrow in the picture.
- Properly put two “AA” batteries into steering wheel and then cover it.

3. Notice while replacing battery

- Non-rechargeable batteries are not to be recharged.
- Rechargeable batteries are to be removed from the toy before being charged.
- Different types of batteries or new and used batteries are not to be mixed. Exhausted batteries are to be removed from the toy.
- Only batteries of the same or equivalent type as recommended are to be used.
- Batteries replaced by children should be under adults’ supervision. Please do not swap the batteries’ poles over. Short circuit

should not occur to the electrical source.

- Please take out batteries in case of leakage and corrosion if long term storage.
- Please take out batteries when it is power off.
- The controller should be operated by adults or should be supervised by adults if played by children.

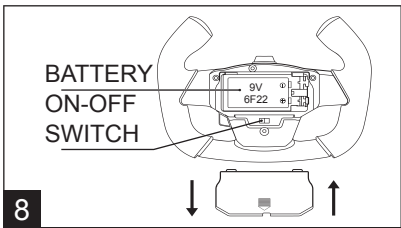

8

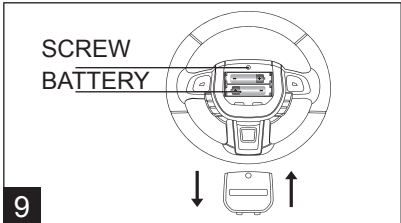

9

NORMAL OPERATION

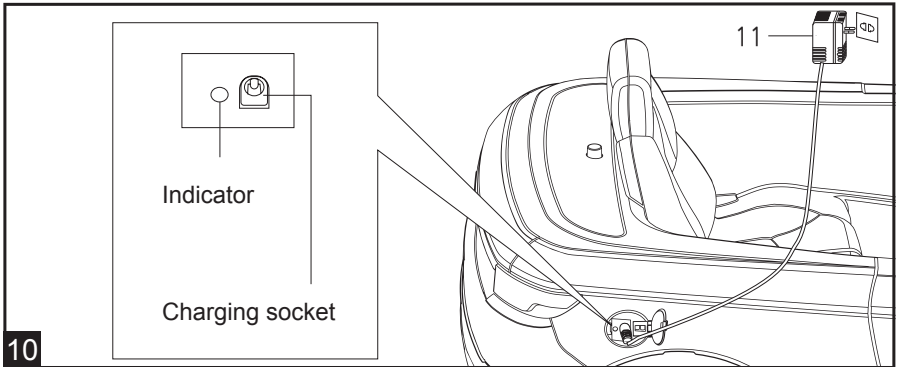

10

- Charging socket is under the filler cap. Open the filler cap and insert the plug of charger, then connect the charger with power.
- Every one hour's running needs 10 to 15 hours' charging. Every single charging can not over 24 hours.
- Both charger and storage batteries will occur mildly warm during charging.
- Do not use mal-functioned adapter or storage battery unless they are repaired.
- This manual has to be kept since it contains important information.
- Charger and storage batteries are not considered as toys.
- Please make periodical inspection for storage battery, especially for adapter wires and plugs.
- Please turn off the switch when the ride-on is not in use. Please make full charging after long-term suspended.
- ONLY use the charger (6V 500mA) supplied by Rastar or Rastar Baby.

STORAGE BATTERY MAINTENANCE

- Please charge 10 to 15 hours before first time use.
- Please use the suitable adapter to charge storage battery, otherwise the ride-on will be damaged.
- Please charge the car once the speed is slower than normal, otherwise it will decrease storage battery life.
- Please fully charge the battery before you put your ride-on away, and remember to recharge the battery every 30 days. This will ensure the normal use of the battery, otherwise, the battery can not be charged.
- For safety, please ONLY use the battery supplied by Rastar or Rastar Baby, which has been protected with polarity anti-reverse structure.

OVERCURRENT PROTECTOR

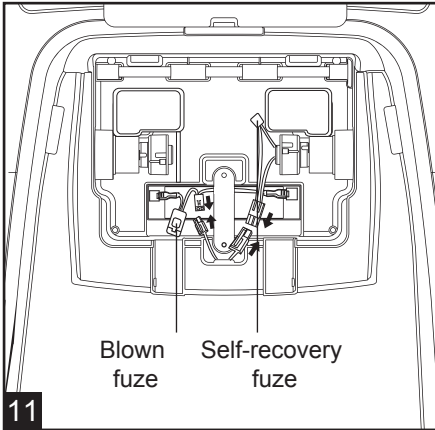

- Overcurrent protector is installed under the seat.
- Rear motor is equipped with self-recovery fuze. Once overloading or improper operation happens, the fuze will automatically cut off the power. Please turn the key off and wait for 30 seconds, then the fuze will recover automatically.
- Power device is equipped with blown fuze. When short-circuit happens, the fuze will be blown. Therefore, after solve the circuit problem, you need to replace the blown fuze.

OPERATING FUNCTION

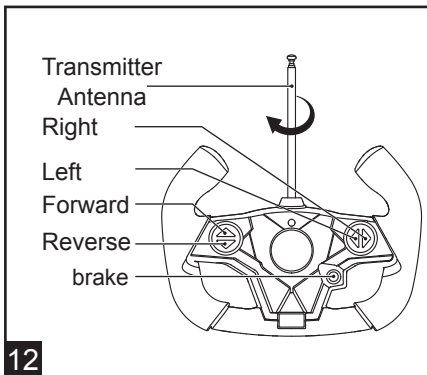

1. Transmitter

- Transmitting signal can cover about 20-30 meters across. If transmitter does not perform properly within this coverage, please check its battery.

Remark: in order to protect the motor, the power of left/right button on the transmitter will be cut off if you press left/right button for over 2 seconds. Therefore, a continuous turning will require you to press left/right button repeatedly.

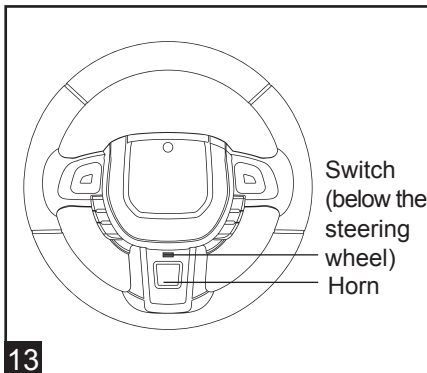

2. Steering wheel

- Switch: switch of controlling horn
- Horn: Horn sound can be activated when press.

CAUTION!
RISK OF FIRE. Do not bypass. Replace only with 250V 20A.

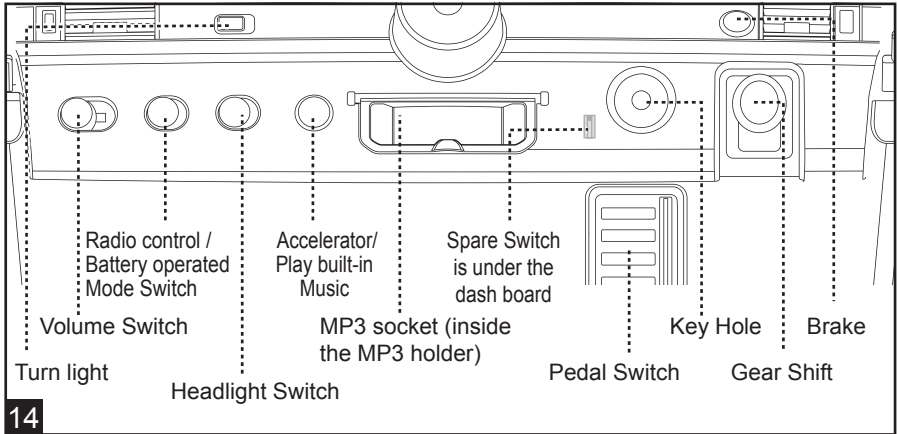

Ride-on Function

Insert the key into the key hole, then turn the key until you hear a click sound.

Forward at high speed: put the Gear Switch in D2 gear and step on pedal switch, the ride-on will move forward at high speed.

Forward at low speed: put the Gear Switch in D1 gear and step on pedal switch, the ride-on will move forward at low speed.

Stop: put the Gear Switch in STOP gear, the ride-on will stop moving.

Reverse: put the Gear Switch in R gear and step on pedal switch, the ride-on will move backward.

Left: steer left the steering wheel when ride-on is moving forward.

Right: steer right the steering wheel when ride-on is moving forward.

Brake: The car stops when press the brake switch during working.

Spare switch is under the instrument. It has the same function as the key switch. Switch up for power off, and down for power on. The ride-on is operated when either the key switch or the spare switch is turned on. Only when both of the switches are turned off, the ride-on will be shut down.

Radio control /Battery operated Mode Switch

The pedal switch, gear shift will be inactive when you switch to Remote Control Mode. To avoid scaring the child while ride-on starts to run forward/reverse, the remote control operation is equipped with low speed start function.

NOTICE!

When not playing MP3, please pull the MP3 Input Wire out of MP3 socket. Otherwise, all other sound effect will be mute.

WARNING

Please read carefully since it contains important information.

- Children are not allowed to operate charging. It should be operated by adult.
- Ride-on operation should be under adults' supervision.
- This product should be assembled by adult; or checked by adult to make sure proper assembly.
- It is prohibited to run this ride-on in public streets, roads, slope, near swimming pool, or any other dangerous area.
- This ride-on can not be overloaded. The maximum loading capacity is 25 kilograms.
- This ride-on is for children age between 37months old - 96months old.
- Some accessories of ride-on may be damaged by improper operation.
- Do not suddenly use forward-reverse switch during running. It can only be used when the ride-on is stopped.
- Swab ride-on with cloth. Do not flush the ride-on with water in case damage.
- Charger is not considered as toy. Please put it away after charging.
- This product is made of plastics. Please keep it away from fire.
- Re-start of the motor may occur sparkles. It is prohibited to run in flammable and explosive area such as gas station.
- Do not let children touch wheels in case being trapped or crushed. Please keep other children away from the ride-on during running.
- Flat ground is good for ride-on running. Please avoid running on sand or any other rough ground.
- The package of ride-on is not toy for children.
- Adults are required to read this instruction carefully and give correct guideline to children before playing.
- This seat belt is only a decoration to develop the safety sense of children, it can not provide any substantial protection.
- Please guide children how to start and relax the pedal, how to handle malfunctions and how to stop ride-on.
- Do not use the malfunctioning ride-on until it is well repaired.

CAUTION!

You may find battery damage, liquid leakage and other dangerous phenomenon during replacement. Please pay attention to the following:

- One 9V battery is needed for this ride-on.
- Battery replacement should be operated by adults.
- Install batteries correctly according to their polarity .
- Storage battery can be removed from the ride-on and recharged, but can NOT be heated or disposed of in fire.
- Non-rechargeable batteries are not to be recharged. Rechargeable batteries

can be recharged under adults' supervision; Rechargeable batteries are to be taken out from ride-on during charging.

- When batteries are short of power, the remote control distance will be shorten. Please replace with new batteries.
- Take out batteries if ride-on is not in use for an extended period in case liquid leakage. Remove batteries when they are used up.
- Supply terminals are not to be short-circuit.
- This ride-on is not for children under 36 months since it may have small parts that can detach during running.
- Transmitter can only be operated by adults or under adults' supervision.

CARE AND MAINTENANCE

- Please do not play until it is fixed perfectly if there is any damaged.
- Please check and maintain the car in regular time for keeping your child safe.
- Please periodically check and make sure there are no screws loosening and spare parts damaged.
- Before installing and using the car, please check all spare parts carefully.
- For avoiding unnecessary damages, please read this instruction in detail before assembly and disassembly.

MALFUNCTION SHOOTING GUIDE

Malfunction	Analysis	Solution
Car is not running	<ul style="list-style-type: none"> ● Storage battery connectors are not well connected ● Gear shift is in the wrong place ● Car is over-loaded ● Main body circuit is damaged 	<ul style="list-style-type: none"> ● Reconnect ● Gear shift should be in the forward or backward position ● Reduce loaded weight to under 25KGS ● Please ask after-sale service for help
Car runs in low speed	<ul style="list-style-type: none"> ● Storage battery power is low ● Ground is uneven 	<ul style="list-style-type: none"> ● Fully charge battery ● Choose an even place
Battery cannot be charged	<ul style="list-style-type: none"> ● Battery connectors are not well connected ● Charger is not charged with electricity ● Charger is broken 	<ul style="list-style-type: none"> ● Reconnect ● Reconnect ● Replace charger

Malfunction	Analysis	Solution
Car cannot stop	<ul style="list-style-type: none"> ● Car is damaged 	<ul style="list-style-type: none"> ● Please ask after-sale service for help
Continue range is short	<ul style="list-style-type: none"> ● Battery is not fully charged ● Battery is over used 	<ul style="list-style-type: none"> ● Re-charge ● Replace battery
Faint sound and heat occurs when charging battery	<ul style="list-style-type: none"> ● Chemical reaction 	<ul style="list-style-type: none"> ● Normal reaction
Gear box is noisy	<ul style="list-style-type: none"> ● Gear is broken 	<ul style="list-style-type: none"> ● Please ask after-sale service for help
Power led is off	<ul style="list-style-type: none"> ● Car power switch is off ● Battery is power-off 	<ul style="list-style-type: none"> ● Turn on the power switch ● Charge the battery
Charger led is off	<ul style="list-style-type: none"> ● Charger is broken 	<ul style="list-style-type: none"> ● Please ask after-sale service for help

**RIDE-ON ELETRICAL ILLUSTRATION
(Transmitter-operted / Pedal-operated)**

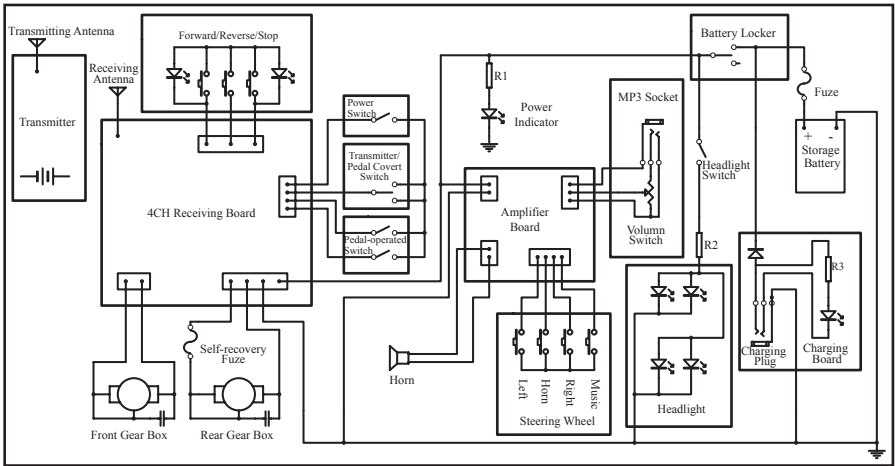

Remark: Specification may vary from this eletrical illustration.

MAINTENANCE

- This product comes with maintenance service.
- Maintenance fee is required for product malfunction caused by improper operation or man-made factor, or if it has exceeded guarantee.
- Maintenance service can be provided by the seller and us. Invoice, maintenance record and malfunctioning product/part(s) will be required.

MAINTENANCE RECORD

Date	Details	Result	Remark

Customer Name: _____

Tel: _____

Address: _____

Item NO.: _____

Invoice NO.: _____



Rastar Baby

Land Rover and the Land Rover Logo are trademarks owned and licensed by Jaguar Land Rover Limited.

Licensee: XINGHUI AUTO MODEL CO.,LTD.

Manufacturer: XINGHUI BABY SUPPLIES CO.,LTD.

Add : North Area, Zhaoan Industrial Park, Zhangzhou, Fujian, China.

[Http://www.rastar.cn](http://www.rastar.cn)